

**SINGLE BALL RACEWAY CASTERS**

**FEATURES**

- Single Ball Race
- Side Brakes Available



See Mounting Options Below

4030-01-SR-SB  
w/optional brake



4030R-01-HR

Single level, ball bearing swivel with a large king pin for economy and long life. These durable casters are designed for heavy loads, limited travel distances and low cost.

WHEEL DIAMETER	TREAD WIDTH	DYNAMIC LOAD	PART #		WHEEL MATERIAL	SWIVEL RADIUS	LOAD HEIGHT
			SWIVEL	RIGID			
2"	15/16"	90 lbs.	4020-01-SR	4020R-01-SR	Soft Rubber · N.B.	1-3/4"	2-7/16"
		125 lbs.	4020-01-HR	4020R-01-HR	Hard Rubber · N.B.		
			4020-01-STL	4020R-01-STL	Steel · P.B.		
2-1/2"	1-1/16"	100 lbs.	4025-01-SR	4025R-01-SR	Soft Rubber · N.B.	2-3/8"	3-1/4"
		175 lbs.	4025-01-HR	4025R-01-HR	Hard Rubber · N.B.		
3"	1-1/4"	125 lbs.	4030-01-SR	4030R-01-SR	Soft Rubber · N.B.	2-7/16"	3-3/4"
		250 lbs.	4030-01-HR	4030R-01-HR	Hard Rubber · N.B.		
4"	1-1/4"	200 lbs.	4040-01-SR	4040R-01-SR	Soft Rubber · N.B.	2-9/32"	5"
		300 lbs.	4040-01-HR	4040R-01-HR	Hard Rubber · N.B.		

N.B. = Nylon Bearing P.B. = Plain Bore

**Mounting Options**

(not to Scale)

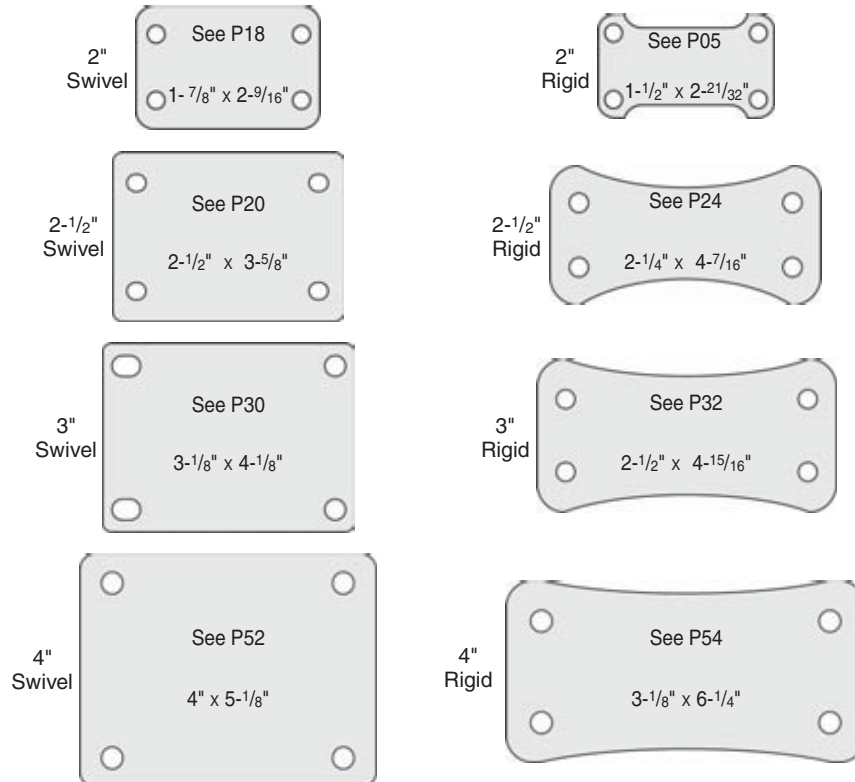

# INSTITUTIONAL CASTERS

## PLATE CASTERS

### FEATURES

- Zinc Plated Finish
- Full Double Ball Hardened Raceways
- 3/8" Greasable Axles
- Rigid Caster in Standard P20 Plate Only



2.05208.91

Rigid Caster



2.05256.441

See Mounting Options Below

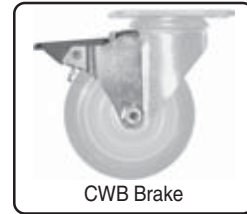

CWB Brake

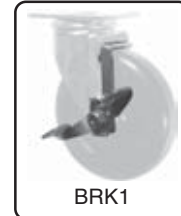

BRK1

See brake section

Colson manufactures an exceptional caster. Colson casters cost a little more but most of our customers agree that the cost of down time of equipment and replacing inferior casters far outweighs the small increase in price. Optional wheel and swivel 'Total Lock' available.

WHEEL DIAMETER	TREAD WIDTH	DYNAMIC LOAD	PART #		WHEEL MATERIAL	WHEEL BEARING	SWIVEL RADIUS	LOAD HEIGHT
			SWIVEL	RIGID				
2-1/2"	1-1/4"	140 lbs.	2.02256.441	2.02208.441	Performa	Delrin	2-13/32"	3-7/8"
		200 lbs.	2.02256.53	2.02208.53	Polyolefin	Delrin		
		250 lbs.	2.02256.91	2.02208.91	Polyurethane	Delrin		
			2.02256.95	2.02208.95	Polyurethane	Ball		
3-1/2"	1-1/4"	230 lbs.	2.03256.53	2.03208.53	Polyolefin	Delrin	2-29/32"	4-11/16"
		250 lbs.	2.03256.441	2.03208.441	Performa	Delrin		
			2.03256.445	2.03208.445	Performa	Ball		
			2.03256.91	2.03208.91	Polyurethane	Delrin		
			2.03256.95	2.03208.95	Polyurethane	Ball		
		300 lbs.	2.03256.12	2.03208.12	Semi Steel	Plain Bore		
4"	1-1/4"	275 lbs.	2.04256.53	2.04208.53	Polyolefin	Delrin	3-7/32"	5-1/8"
			2.04256.55	2.04208.55	Polyolefin	Ball		
			2.04256.91	2.04208.91	Polyurethane	Delrin		
			2.04256.95	2.04208.95	Polyurethane	Ball		
		300 lbs.	2.04256.12	2.04208.12	Semi Steel	Plain Bore		
			2.04256.441	2.04208.441	Performa	Delrin		
5"	1-1/4"	250 lbs.	2.05256.561	2.05208.561	Performa Rd.	Delrin	3-13/16"	6-3/16"
			2.05256.565	2.05208.565	Performa Rd.	Ball		
		300 lbs.	2.05256.12	2.05208.12	Semi Steel	Plain Bore		
			2.05256.53	2.05208.53	Polyolefin	Delrin		
			2.05256.91	2.05208.91	Polyurethane	Delrin		
			2.05256.95	2.05208.95	Polyurethane	Ball		
		325 lbs.	2.05256.441	2.05208.441	Performa	Delrin		
			2.05256.445	2.05208.445	Performa	Ball		

### Mounting Options (Not to Scale)

2-1/2" Casters available with standard P20 plate only.

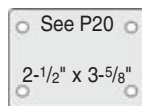

Standard Plate

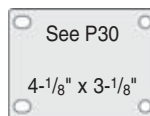

Plate Option MTG59

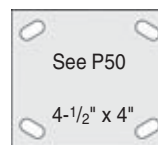

Plate Option MTG27

**SPECIAL PLATE CASTERS**

**FEATURES**

- Zinc Plated Finish
- Full Double Ball Hardened Raceways
- 3/8" Greasable Axles



5-30-53-SP

See Mounting Options Below

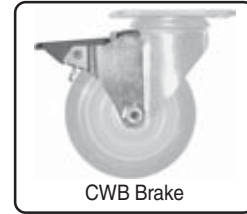

CWB Brake



TLB Brake

See brake section

The P27 plate is specially designed to replace food service legs. The bolt hole pattern is 2-5/8" square. The plate is attached to a quality 5" x 1-1/4" NSF approved rig. For most applications the Polyolefin wheel is the most popular wheel choice. The P26 plate is used for high temperature bake oven applications. Rigid casters are not available.

WHEEL DIAMETER	TREAD WIDTH	MOUNTING CODE	DYNAMIC LOAD	PART #	WHEEL MATERIAL	WHEEL BEARING	SWIVEL RADIUS	LOAD HEIGHT
4"	1-1/4"	P26	300 lbs.	5040-03-52HT	Thermo Resin	Plain	3-1/2"	5"
5"		P27	325 lbs.	5-30-441-SP	Performa	Delrin	4"	6-1/4"
	5-30-445-SP			Performa	Ball			
	5-30-53-SP			Polyolefin	Delrin			
	5-30-91-SP			Polyurethane	Delrin			

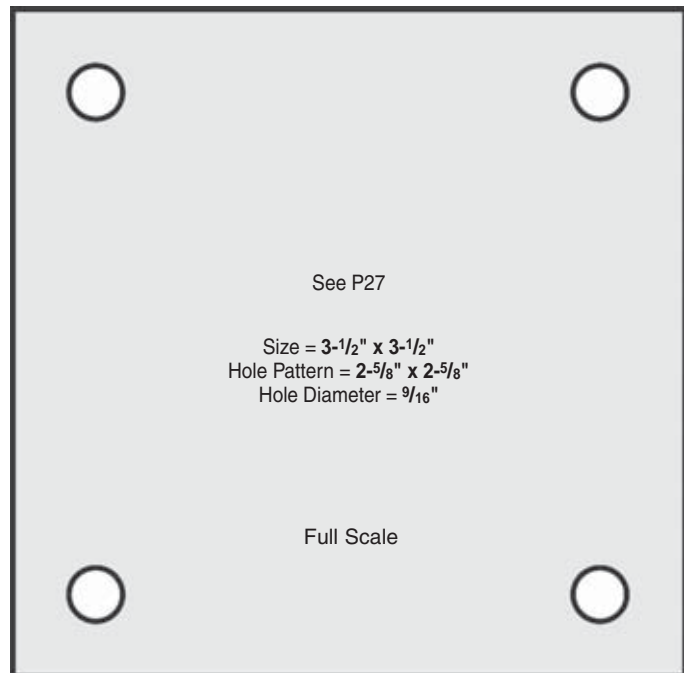
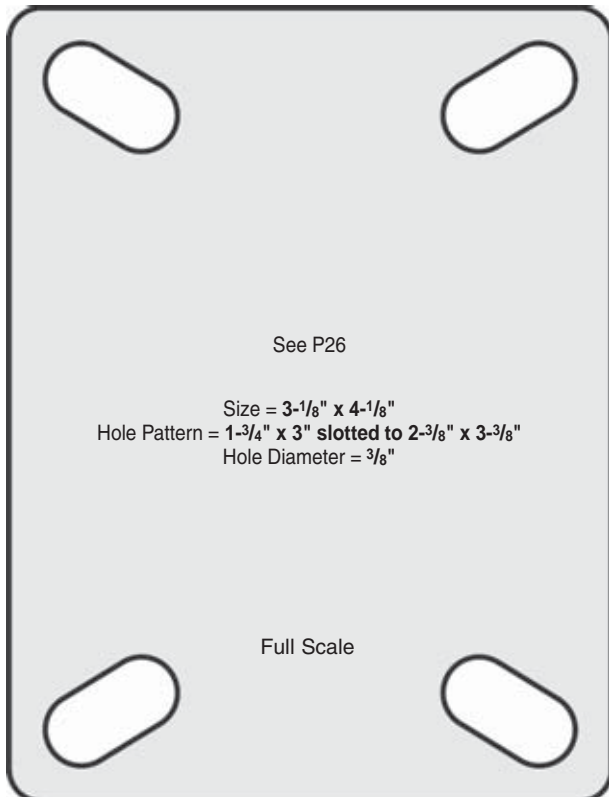

# INSTITUTIONAL CASTERS THREADED STEM CASTERS

## FEATURES

- Zinc Plated Finish
- Full Double Ball Hardened Raceways
- 3/8" Greasable Axles
- NSF Approved

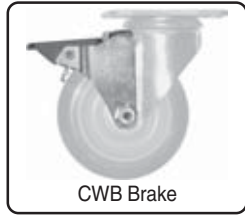

See brake section



2.05254.95 T10

## Mounting Options (Not Full Scale)

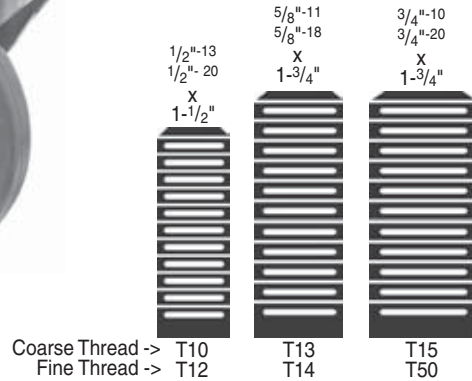

The threaded stem is a convenient method for attaching a castor where limited mounting space makes a plate mount impossible. When leveling is required a spacer washer should be placed between the top of the castor and the mounting frame to give full support to the castor.

WHEEL DIAMETER	TREAD WIDTH	DYNAMIC LOAD	PART #	WHEEL MATERIAL	WHEEL BEARING	SWIVEL RADIUS	LOAD HEIGHT
2-1/2"	1-1/4"	140 lbs.	2.02254.441	Performa	Delrin	2-13/32"	3-3/4"
		200 lbs.	2.02254.53	Polyolefin	Delrin		
		250 lbs.	2.02254.91	Polyurethane	Delrin		
			2.02254.95	Polyurethane	Ball		
3-1/2"	1-1/4"	230 lbs.	2.03254.53	Polyolefin	Delrin	2-29/32"	4-9/16"
		250 lbs.	2.03254.441	Performa	Delrin		
			2.03254.445	Performa	Ball		
			2.03254.91	Polyurethane	Delrin		
			2.03254.95	Polyurethane	Ball		
		300 lbs.	2.03254.12	Semi Steel	Plain Bore		
4"	1-1/4"	275 lbs.	2.04254.53	Polyolefin	Delrin	3-7/32"	5"
			2.04254.55	Polyolefin	Ball		
			2.04254.91	Polyurethane	Delrin		
			2.04254.95	Polyurethane	Ball		
		300 lbs.	2.04254.12	Semi Steel	Plain Bore		
			2.04254.441	Performa	Delrin		
			2.04254.445	Performa	Ball		
5"	1-1/4"	250 lbs.	2.05254.561	Performa Rd.	Delrin	3-13/16"	6-1/16"
			2.05254.565	Performa Rd.	Ball		
			2.05254.53	Polyolefin	Delrin		
		300 lbs.	2.05254.12	Semi Steel	Plain Bore		
			2.05254.91	Polyurethane	Delrin		
			2.05254.95	Polyurethane	Ball		
			2.05254.441	Performa	Delrin		
		325 lbs.	2.05254.445	Performa	Ball		

**EXPANDING STEM CASTERS**

**FEATURES**

- Zinc Plated Finish
- Full Double Ball Hardened Raceways
- 3/8" Greasable Axles
- 1/2" x 2-11/16" Threaded Stem
- NSF Approved



2.05267.441 (APP46)

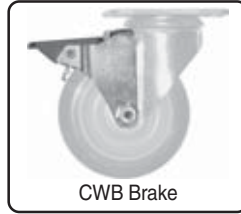

CWB Brake



BRK1

See brake section

Stem w/o adapter  
1/2" x 2-11/16"



Expanding Rubber Adapters

CODE	INSIDE DIAMETER
APP40	3/4" -> 13/16"
APP41	7/8" -> 31/32"
APP42	1" -> 1-3/32"
APP43	1-1/8" -> 1-3/16"
APP44	1-1/4" -> 1-5/16"
APP45	1-3/8" -> 1-7/16"
APP46	1-7/16" -> 1-37/64"
APP47	1-5/8" -> 1-23/32"

For use on food service carts, dish carts, process tables and commercial kitchen equipment. These stems are made for food handling equipment. The rubber expanding adapter kits are made to fit the most popular tubing sizes in the food handling field.

WHEEL DIAMETER	TREAD WIDTH	DYNAMIC LOAD	PART #	WHEEL MATERIAL	WHEEL BEARING	SWIVEL RADIUS	LOAD HEIGHT
3"	1-1/4"	125 lbs.	3-40-SR	Soft Rubber	Plain	3"	3-15/16"
		210 lbs.	3-40-HR	Hard Rubber	Plain		
		220 lbs.	3-40-PLY	Polyurethane	Ball		
		250 lbs.	3-40-HDP	H.D. Plastic	Plain		
3-1/2"	1-1/4"	230 lbs.	2.03267.53	Polyolefin	Delrin	2-29/32"	4-9/16"
		250 lbs.	2.03267.441	Performa	Delrin		
			2.03267.445	Performa	Ball		
			2.03267.91	Polyurethane	Delrin		
		2.03267.95	Polyurethane	Ball			
300 lbs.	2.03267.12	Sem i Steel	Plain				
4"	1-1/4"	275 lbs.	2.04267.53	Polyolefin	Delrin	3-7/32"	5-1/4"
			2.04267.55	Polyolefin	Ball		
			2.04267.91	Polyurethane	Delrin		
		300 lbs.	2.04267.95	Polyurethane	Ball		
			2.04267.12	Sem i Steel	Plain		
			2.04267.441	Performa	Delrin		
5"	1-1/4"	250 lbs.	2.05267.561	Performa Rd.	Delrin	3-13/16"	6-5/16"
			2.05267.565	Performa Rd.	Ball		
		300 lbs.	2.05267.12	Sem i Steel	Plain		
			2.05267.53	Polyolefin	Delrin		
			2.05267.91	Polyurethane	Delrin		
			2.05267.95	Polyurethane	Ball		
325 lbs.	2.05267.441	Performa	Delrin				
	2.05267.445	Performa	Ball				

# INSTITUTIONAL CASTERS PIPE THREAD CASTERS

## FEATURES

- Zinc Plated Finish
- Full Double Ball Hardened Raceways
- 3/8" Greasable Axles



2.05053.91-3/4"

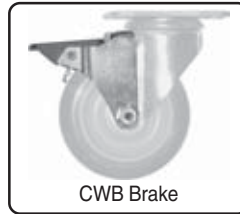

CWB Brake



BRK1

See brake section

## Mounting Options

(Full Scale)

3/4" Pipe Thread



T75

1" Pipe Thread

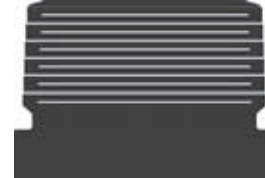

T100

1-1/4" Pipe Thread



T125

Specify Size

The pipe stem screws directly into standard pipe couplings providing full swivel action. Pipe thread stems have a slight taper.

WHEEL DIAMETER	TREAD WIDTH	DYNAMIC LOAD	PART #	WHEEL MATERIAL	WHEEL BEARING	SWIVEL RADIUS	LOAD HEIGHT
3"	1-1/4"	125 lbs.	3-38-SR-(SIZE)	Soft Rubber	Self lube	3"	4-1/8"
		210 lbs.	3-38-HR-(SIZE)	Hard Rubber	Self lube		
		300 lbs.	3-38-HDP-(SIZE)	Polyolefin	Plain Bore		
		220 lbs.	3-38-PLY-(SIZE)	Polyurethane	Ball		
3-1/2"	1-1/4"	250 lbs.	2.03253.53-(SIZE)	Polyolefin	Delrin	2-29/32"	4-13/16"
			2.03253.441-(SIZE)	Performa	Delrin		
			2.03253.445-(SIZE)	Performa	Ball		
			2.03253.91-(SIZE)	Polyurethane	Delrin		
			2.03253.95-(SIZE)	Polyurethane	Ball		
4"	1-1/4"	275 lbs.	2.04253.53-(SIZE)	Polyolefin	Delrin	3-7/32"	5-1/4"
			2.04253.55-(SIZE)	Polyolefin	Ball		
			2.04253.91-(SIZE)	Polyurethane	Delrin		
			2.04253.95-(SIZE)	Polyurethane	Ball		
		300 lbs.	2.04253.441-(SIZE)	Performa	Delrin		
			2.04253.445-(SIZE)	Performa	Ball		
5"	1-1/4"	250 lbs.	2.05253.561-(SIZE)	Performa Rd.	Delrin	3-13/16"	6-5/16"
			2.05253.53-(SIZE)	Polyolefin	Delrin		
		300 lbs.	2.05253.91-(SIZE)	Polyurethane	Delrin		
			2.05253.95-(SIZE)	Polyurethane	Ball		
		325 lbs.	2.05253.441-(SIZE)	Performa	Delrin		
			2.05253.445-(SIZE)	Performa	Ball		

See Pipe Adapters on pg. 12

**GRIP RING CASTERS**

**FEATURES**

- Zinc Plated Finish
- Full Double Ball Hardened Raceways
- 3/8" Greasable Axles



2.05251.445 (S58)

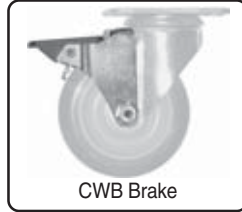

CWB Brake



BRK1

See brake section

**Mounting Options**

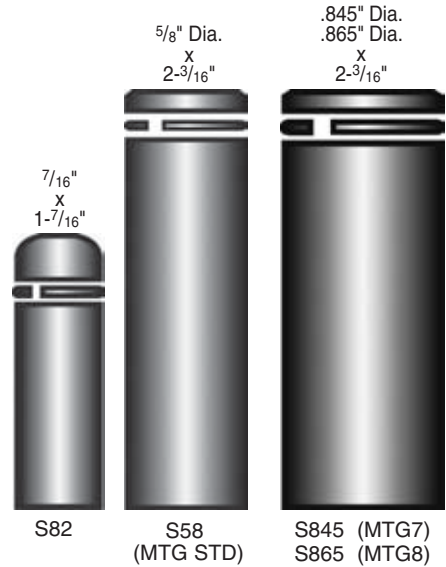

S82

S58 (MTG STD)

S845 (MTG7)  
S865 (MTG8)

Grip ring stems are used on equipment with tubular legs. The stems feature a spring grip at the top to securely hold the caster in place. Please stipulate which of the grip ring stems is required.

**S58, S845, and S865 Stem Casters.**

WHEEL DIAMETER	TREAD WIDTH	DYNAMIC LOAD	PART #	WHEEL MATERIAL	WHEEL BEARING	SWIVEL RADIUS	LOAD HEIGHT
5"	1-1/4"	250 lbs.	2.05251.561-(MTG#)	Performa Round	Delrin	3-13/16"	6-1/16"
			2.05251.565-(MTG#)	Performa Round	Ball		
		300 lbs.	2.05251.12-(MTG#)	Semi Steel	Plain Bore		
			2.05251.53-(MTG#)	Polyolefin	Delrin		
			2.05251.91-(MTG#)	Polyurethane	Delrin		
			2.05251.95-(MTG#)	Polyurethane	Ball		
		325 lbs.	2.05251.441-(MTG#)	Performa	Delrin		
			2.05251.445-(MTG#)	Performa	Ball		

**S82 Stem casters.**

WHEEL DIAMETER	TREAD WIDTH	DYNAMIC LOAD	PART #	WHEEL MATERIAL	WHEEL BEARING	SWIVEL RADIUS	LOAD HEIGHT
3"	1-1/4"	125 lbs.	5430-11-SR	Soft Rubber	Nylon	2-5/8"	3-25/32"
		150 lbs.	5430-11-HR	Hard Rubber	Nylon		
		220 lbs.	5430-11-PLY	Polyurethane	Ball Bearing		
4"	1-1/4"	165 lbs.	5440-11-SR	Soft Rubber	Nylon	3-5/32"	5-5/32"
		230 lbs.	5440-11-PLY	Polyurethane	Ball Bearing		
		255 lbs.	5440-11-HR	Hard Rubber	Nylon		
5"	1-1/4"	175 lbs.	5450-11-SR	Soft Rubber	Nylon	3-11/16"	5-27/32"
		250 lbs.	5450-11-PLY	Polyurethane	Ball Bearing		
		260 lbs.	5450-11-HR	Hard Rubber	Nylon		

See S82 Sockets on pg. 13

# INSTITUTIONAL CASTERS

## MISCELLANEOUS STEM CASTERS

### FEATURES

- Zinc Plated Finish
- Full Double Ball Hardened Raceways
- Nominal 1-1/4" Wheel Tread Width
- 3/8" Greasable Axles



2.05070.561 (S70)

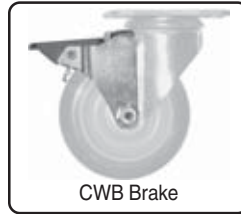

CWB Brake



BRK1

See brake section

### Mounting Options (full Scale)

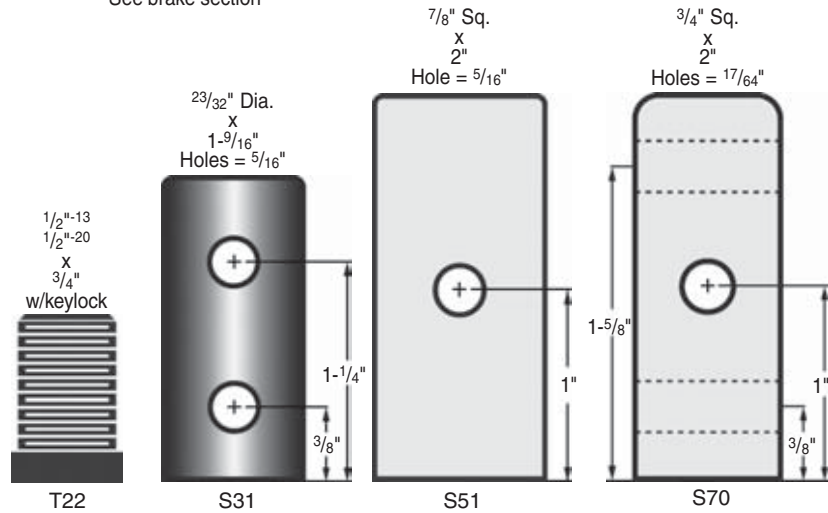

These stems represent some of the more popular special purpose mountings we stock. In addition we stock a large assortment of special purpose mountings. Please call if you don't see what you need.

WHEEL DIAMETER	MOUNTING CODE	DYNAMIC LOAD	PART #		WHEEL MATERIAL	WHEEL BEARING	SWIVEL RADIUS	LOAD HEIGHT
			SWIVEL	RIGID				
3"	S70	125 lbs.	5030-41-SR		Soft Rubber	Nylon	2-7/8"	4"
		220 lbs.	5030-41-PLY		Polyurethane	Ball		
		250 lbs.	5030-41-HDP		H. D. Plastic	Plain Bore		
4"	S70	275 lbs.	2.04270.53		Polyolefin	Delrin	3-7/32"	5"
			2.04270.55		Polyolefin	Ball		
			2.04270.91		Polyurethane	Delrin		
			2.04270.95		Polyurethane	Ball		
		300 lbs.	2.04270.12		Semi Steel	Plain Bore		
			2.04270.441		Performa	Delrin		
			2.04270.445		Performa	Ball		
5"	T22	160 lbs.	8150-22-PLY	8150R-22-PLY	Polyurethane	Ball	3-7/8"	6-15/16"
	S31	160 lbs.	8150-31-PLY	8150R-31-PLY	Polyurethane	Ball		
	S51	175 lbs.	5250-51-SR		Soft Rubber	Nylon	4"	6-3/16"
		250 lbs.	5250-51-PLY		Polyurethane	Ball		
		300 lbs.	5250-51-HDP		H. D. Plastic	Plain Bore		
	S70	250 lbs.	2.05270.561		Performa Rd.	Delrin	3-13/16"	6-1/16"
			2.05270.565		Performa Rd.	Ball		
			2.05270.12		Semi Steel	Plain Bore		
		300 lbs.	2.05270.53		Polyolefin	Delrin		
			2.05270.91		Polyurethane	Delrin		
			2.05270.95		Polyurethane	Ball		
			2.05270.441		Performa	Delrin		
			2.05270.445		Performa	Ball		
			325 lbs.	2.05270.445		Performa		

# INSTITUTIONAL CASTERS

## LOW PROFILE



2.03689.44 B3



2.03689.44



2.03688.44

### FEATURES

- Zinc Plated Finish
- Full Double Ball Hardened Raceways
- 3/8" Axles

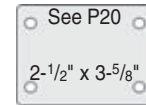

These hard working movers handle the job with a low load height and quick swivel response. Perfect for hand pushed equipment in a wide variety of industrial, institutional and commercial applications.

LoPro casters feature double ball bearing, heat treated raceways and a durable zinc plated finish. The bearing consists of an oil-impregnated, sintered iron bearing riding on the spanner bushing. Brakes are available in the 3" model, add 'B3' to end of part number.

WHEEL DIAMETER	TREAD WIDTH	MOUNTING CODE	DYNAMIC LOAD	PART #		WHEEL MATERIAL	SWIVEL RADIUS	LOAD HEIGHT
				SWIVEL	RIGID			
2 - 1/2"	1- 1/8"	P20	120 lbs.	2.02689.44	2.02688.44	Cushion Rubber	2 - 3/8"	3 - 5/16"
			175 lbs.	2.02689.54	2.02688.54	Hard Rubber		
3"	1- 1/4"	P20	125 lbs.	2.03689.44	2.03688.44	Cushion Rubber	2 - 11/16"	3 - 13/16"
			210 lbs.	2.03689.54	2.03688.54	Hard Rubber		

## BOLT HOLE CASTER

### FEATURES

- Zinc Plated Finish
- Full Double Ball Raceways
- 1/2" Bolt Hole Mounting
- Available with Total Lock
- Available in Stainless Steel



BH-3125-NL-1/2"



Total lock Brake

This caster was designed for applications where it is convenient to use a 1/2" bolt. It also makes it ideal for unusual stem mounts that can be made to customer specifications. Double ball raceway construction and zinc plating are standard.

WHEEL DIAMETER	TREAD WIDTH	MOUNTING CODE	DYNAMIC LOAD	PART #	WHEEL MATERIAL	SWIVEL RADIUS	LOAD HEIGHT
3"	1- 1/4"	1/2" Bolt Hole	150 lbs.	BH-3125-S-1/2"	Soft Rubber	2 - 11/16"	4 - 1/16"
			300 lbs.	BH-3125-NL-1/2"	Ny-Lite (Nylon)		
			300 lbs.	BH-3125-UC-RB-1/2"	Urethane on Cast		
4"	1- 1/4"		150 lbs.	BH-4125-S-1/2"	Soft Rubber	3 - 1/2"	5 - 1/16"
			300 lbs.	BH-4125-NL-1/2"	Ny-Lite (Nylon)		
	350 lbs.		BH-4125-UC-RB-1/2"	Urethane on Cast			
5"	1- 1/2"		270 lbs.	SSBH-220-100-NL-1/2"	Ny-Lite (Nylon)	4 - 1/8"	6 - 1/8"
	1- 3/8"		225 lbs.	BH-5125-S-1/2"	Soft Rubber		
			350 lbs.	BH-5125-NL-1/2"	Ny-Lite (Nylon)		
		400 lbs.	SSBH-220-125-NL-1/2"	Ny-Lite (Nylon)			
	1- 1/2"	450 lbs.	BH-5125-UC-RB-1/2"	Urethane on Cast			

# INSTITUTIONAL CASTERS

## STAINLESS STEEL INSTITUTIONAL CASTERS

### FEATURES

- Polished Stainless Steel Finish Handles The Most Corrosive Conditions.
- Double Ball Raceways for Better Performance and Greater Durability.
- 3/8" Stainless Steel Axles.

### OPTIONS

- BRK2 Tech Lock Brake (field installable)
- TG2 Thread Guards



2.04456.944



2.04408.444

Stainless Steel offers the perfect solution to wet and corrosive environments. These casters are suitable for applications such as meat, fish and poultry plants; dairies; laundries; laboratories; food manufacturing; hospitals; bakeries; restaurants and a variety of institutions. The load capacities range up to 325 lbs.

WHEEL DIAMETER	TREAD WIDTH	DYNAMIC LOAD	PART #		WHEEL MATERIAL	SWIVEL RADIUS	LOAD HEIGHT
			SWIVEL	RIGID			
3"	1-1/4"	140 lbs.	5130-01-PLY	5130R-01-PLY	Polyurethane Plain Bore	2-7/8"	4"
		155 lbs.	5130-01-MIR	5130R-01-MIR	Mirage Rubber		
		250 lbs.	5130-01-NYL	5130R-01-NYL	Nylon		
4"	1-1/4"	200 lbs.	2.04456.544	2.04408.544	Polyolefin	3-5/16"	5-1/8"
		250 lbs.	2.04456.944	2.04408.944	Polyurethane HI-TECH		
			5130-01-PLY	5130R-01-PLY	Polyurethane Plain Bore		
			5130-01-MIR	5130R-01-MIR	Mirage Rubber		
		300 lbs.	2.04456.444	2.04408.444	Performa Rubber (Flat/Gray)	3-5/16"	5"
			5130-01-NYL	5130R-01-NYL	Nylon	3-1/2"	
5130-01-MIR	5130R-01-MIR		Mirage Rubber	3-1/2"			
5"	1-1/4"	200 lbs.	2.05456.544	2.05408.544	Polyolefin	4-1/16"	6-3/16"
		250 lbs.	2.05456.944	2.05408.944	Polyurethane HI-TECH		
			5130-01-PLY	5130R-01-PLY	Polyurethane Plain Bore		
			5130-01-MIR	5130R-01-MIR	Mirage Rubber		
		300 lbs.	5130-01-NYL	5130R-01-NYL	Nylon	4"	6"
			5130-01-MIR	5130R-01-MIR	Mirage Rubber		
5130-01-NYL	5130R-01-NYL		Nylon				
325 lbs.	2.05456.444	2.05408.444	Performa Rubber (Flat/Gray)	4-1/16"	6-3/16"		

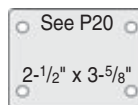

Standard Plate

## WHEEL BRAKES



Foot actuated side brake found on the light duty and general duty casters. Braking action is produced by the compression of the wheel hub providing limited braking ability with all wheels. These brakes are not normally field installable.



Colson foot actuated light duty brake. The ends of brake spring are crimped so that they grab the wheel at four contact points. They provide extra holding power on a variety of wheel surfaces.



Standard tread lock brakes available on institutional casters. Brake is easily operated with foot action and provides positive braking. Limited braking ability when used with hard wheels.



Surface contact brake available for institutional casters. Easily operated with foot action. Metal edge on brake makes contact with the tread providing positive braking action. Limited braking ability when used with hard wheels.



Surface contact brake available for truck duty casters. Easily operated with foot action. Metal edge on brake makes contact with the tread providing positive braking action. Limited braking ability when used with hard wheels.



Surface contact brake for use on truck duty casters recommended for both hard and soft tread wheels. Foot actuated rubber pad on brake makes contact with wheel tread providing positive braking.



Surface contact brake for use on truck duty casters recommended for both hard and soft tread wheels. Foot actuated adjustable pad on brake makes contact with wheel tread providing positive braking.



Surface contact brake supplied on our heavy duty casters. Foot actuated cam provides positive braking and adjustment for wheel wear. Works well with hard and soft wheel treads. Brake is welded to fork, not field installable.



Machine caster brake used to immobilize heavy office machinery. When machinery is in place the thumb screw is tightened to stop all wheel movement.



## TOTAL LOCK

Simply pressing the pedal locks the swivel and wheel in any position. A total lock is called for when the equipment must be free of all movement however slight. Available for truck duty and institutional casters. Not field installable in most cases.



## SWIVEL ONLY

Effectively converts a swivel caster to a rigid caster when required. Provides better tracking when moving equipment, when needed the lock is disengaged to allow for swivel motion. The wheel is unaffected by the swivel locking mechanism. Not field installable in most cases.

